

NASTRO-SB™ - R8

The Next Benchmark



NASTRO-SB™ - R8

Nastro-SB™ R is a range of semi-automatic case sealing machines designed and engineered by SIAT specifically for king random boxes. Nastro-SB™ R is the ideal case sealing machine for a variety of industries like food&beverage, chemical, clothes and e-commerce.

SPECIFICATIONS

Max Production Capacity: 750 boxes/hour

Case type: RSC - FEFCO 0201

Max case weight: 32 kg

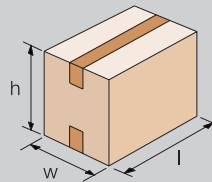

| Box dimensions | L (mm) | W (mm) | H (mm) |
|----------------|---------|-----------|-----------|
| R8B-S / R8T-S | 150 - ∞ | 150 - 800 | 90* - 800 |
| R8B-L / R8T-L | 150 - ∞ | 105 - 800 | 50* - 800 |

* with 30 mm tape leg

KEY FEATURES

- » Lockable power switch
- » Double side emergency buttons
- » Removable heads without tools
- » 75 mm high belt conveyor
- » Easy to replace belt without removing the conveyor
- » 50 mm minimum box height (with L version)
- » Full Festo pneumatics
- » Linear belt conveyor movement
- » It can be equipped with IoT System
- » Faster than standard case sealers thanks to patented variable speed functions

ENERGY SAVING

Motors and conveyors stop after a defined time when no cartons are detected

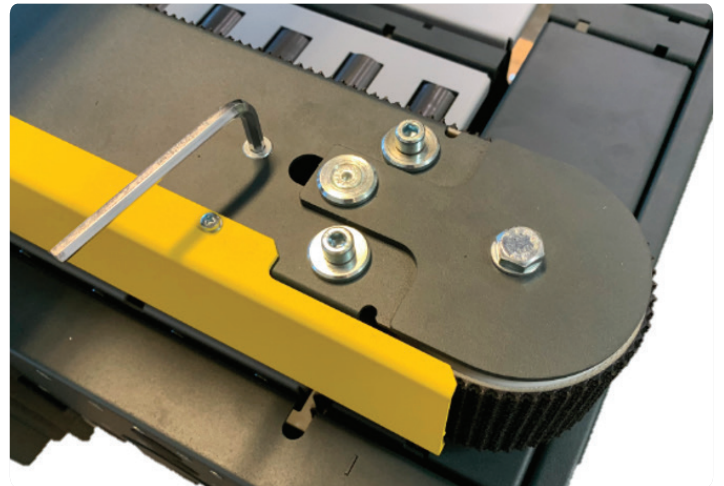

Safety fences with access door

top taping unit

Emergency button on both sides

Easy to maintain belt conveyor

Festo air filter

New high performance control panel

Top head and belt conveyor pressure regulation mobs

Bottom taping unit

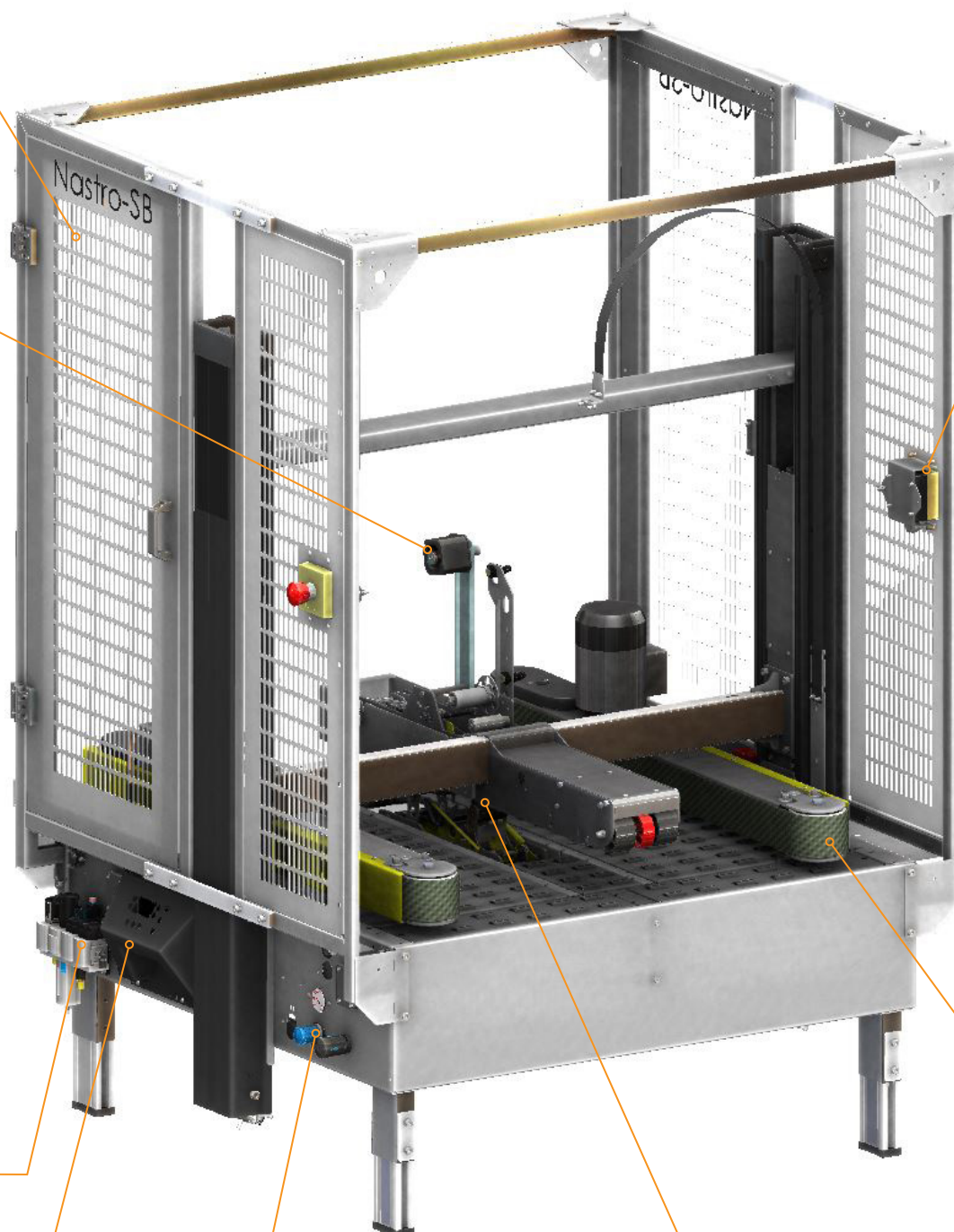



NASTRO-SB™ - R8

Machine dimensions

Dimensioni macchina
Maschinenabmessungen
Dimensions machine
Dimensiones de máquina

| | Model | Min (mm) | Max (mm) |
|---------|-------|----------|----------|
| Total H | R8 | 1835 | 2095 |
| H Bench | ALL | 540 | 800 |
| W | R8 | 1270 | 1270 |
| L | ALL | 1100 | 1100 |

| | | R8 |
|---|---|--------|
|  | | TBD Kg |
|  | | TBD Kg |
|  | L | TBD |
| | w | TBD |
| | H | TBD |

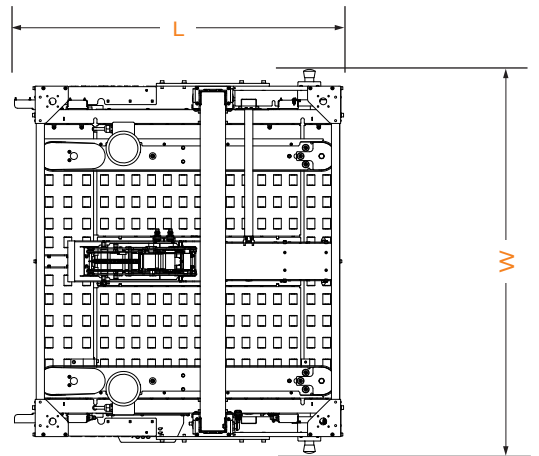
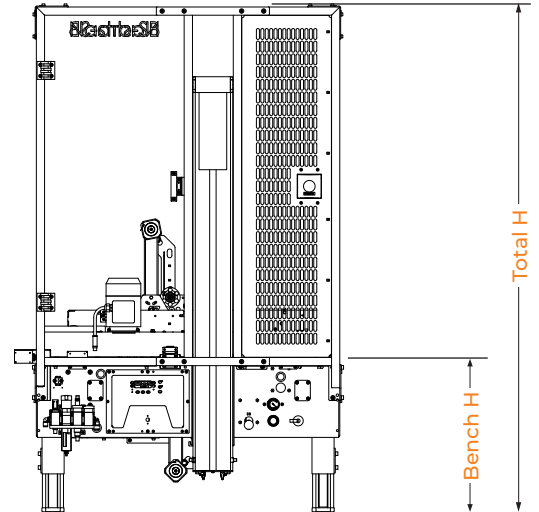
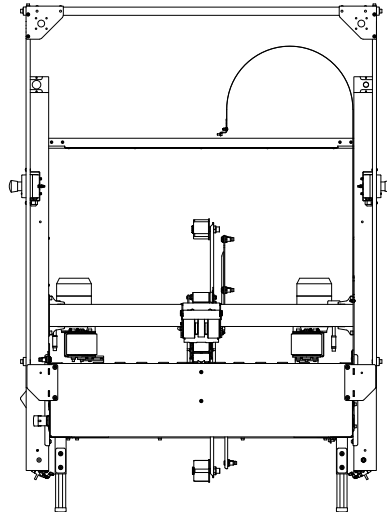

Max Production capacity

Capacità di produzione
Produktionskapazität
Capacité de production
Capacidad de producción

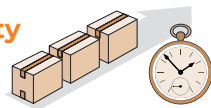

up to 800 Bph

Standard power supply

Alimentazione standard
Standard-Stromanschluß
Alimentation électrique standard
Fuente de alimentación estándar

| | |
|----------------------------|--------------|
| 220/240V - 50/60Hz - 1PH+N | |
| or 440V - 50/60Hz - 3PH+N | |
| Amps | 3,4 |
| Power kW | 0,5 |
| Phase | 1Ph + N + PE |

Optional Extras

Accessori
Zubehör
Accessories
Accesorios

GTL - GTR

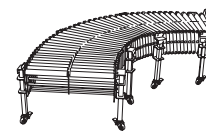

Higher Legs



AS77

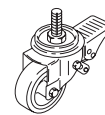

RG



Nastro legs medium height (440-700 mm)
Nastro legs max height (760-1020 mm)



SIAT Spa

Via Puecher 22, 22078 Turate - Como
www.siat.com

 100%
MADE in ITALY

SIAT AND MAILLIS GROUP

SIAT is the famous Italian Brand of strapping hand tools, semi-auto wrappers and case handling machines and proudly part of Maillis Group. Operating 5 production units around the

world and employing over 1,200 qualified staff, Maillis provides you with reliable system solutions incorporating machines, consumables and services to face your everyday challenges across different industries.

SIAT S.p.A is recognised worldwide as a top-class machine manufacturer for secondary packaging and produces more than 17,000 machines per year, and has done since 1970. Our product range includes semi-automatic as well as fully automatic machines like Case Sealers and Case Erectors, Stretch Wrappers, Strapping Tools / Machines, Flexographic Printing Machines and Tape Dispensers. The company is present in more than 100 countries and is constantly investing worldwide to meet customers actual and future demands.