

SIAT

MAILLIS

SM2-I

Stainless Steel Carton Sealing Machine

Reliable sealing process thanks to our taping heads



Sturdy "A frame" structure for heavy duty applications

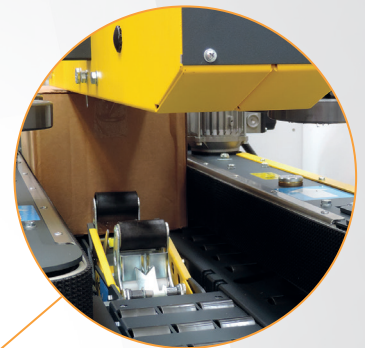

Perfect box control with 2 top + 2 bottom 75mm width side drive belts

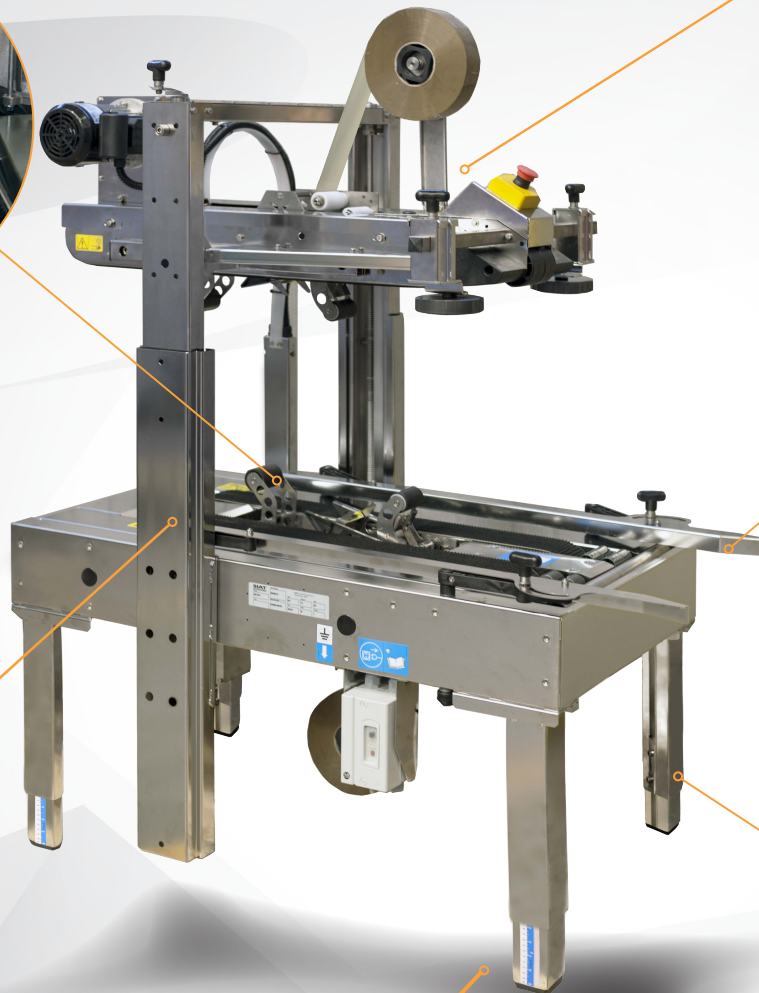

Easy infeed thanks to benchwork rollers



Stainless steel telescopic legs in AISI304

All frame and components built in AISI304 stainless steel with electropolish surface treatment

CE

for more details:



The semi-automatic case sealer **SM2-I** is the stainless steel solution in case of uniform size sealing needs.

Thanks to the strong dual mast frame, completely built in AISI 304, SM2 is suitable for environments where an high cleaning level is required.

In fact, it meets the requirements of food production plants, the controlled environments of pharma and cosmetic businesses in addition to the environments with a high rate of corrosion and dispersion of harsh chemicals.

SM2-I model has been designed in compliance with CE regulations.



other languages: www.siat.com

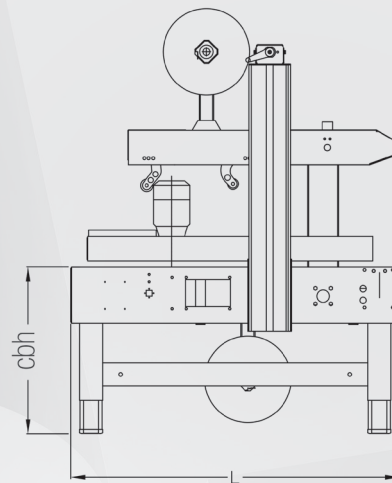
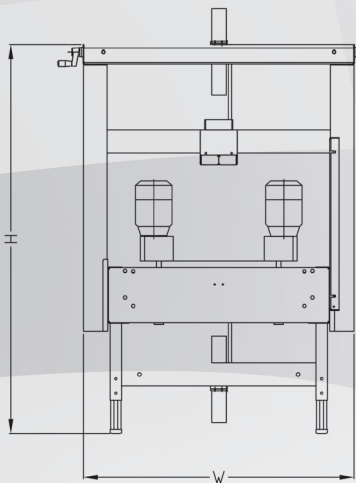

> **Machine dimensions**

Dimensioni macchina
 Machinemessungen
 Dimensions machine
 Dimensiones de máquina

Size / Weight packaging			LxWxH
> SM2-I	185	220	120x106x116

> **SM2-I**

	Min.	Max
L	938	-
W	1140	-
H	1250	1590
cbh	480	820
AS 77	580	920
AS 80	680	1020

> **Taping units**

Unità nastranti
 Verschliesseinheiten
 Unité enrubanneuses
 Unidades de precinto

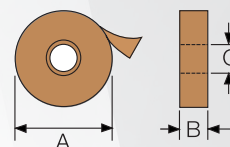

	K11
	mm
A	410 Max
B	50
C	76

> **Box dimensions**

Dimensioni delle scatole
 Kartonabmessungen
 Dimensions des boîtes
 Dimensiones de cajas

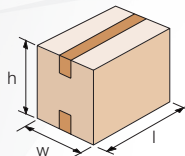

> **SM2-I**

	K11	
	Min.	Max
l	150	∞
w	140 / 170*	500
h	100	500

* With top side pressure rollers (min. width manageable 205mm)
 Upper guides required in case of box width less than 205mm (optional)

> **Production capacity**

Capacità di produzione
 Produktionskapazität
 Capacité de production
 Capacidad de producción

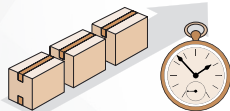

> SM2-I	Bph
Max pcs.*	1200

* Depending on operator dexterity

> **Standard voltage**

Voltaggio standard
 Standardspannung
 Tension standard
 Voltaje estándar

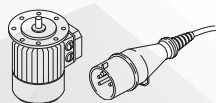

> **SM2-I**

380/415V - 50Hz	
<i>Other voltages available on demand</i>	
Amps	1,08
Power kW	0,26
Phase	3Ph + PE

> **Optionals**

Accessori
 Zubehör
 Accessories
 Accesorios

> **AS80**

Higher legs
 Set gambe più alte
 Höhere Stützen
 Pieds plus hauts
 Patas más altas

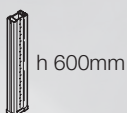

> **AS77**

Castors
 Set ruote
 Rädchen
 Roulettes
 Ruedas

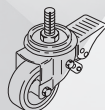

> **RG**

Roller conveyor
 Piani a rulli
 Rollenbahnen
 Plans à rouleaux
 Rodillos libres



> **GTL - GTR**

Extendable conveyor
 Rulliera estensibile
 Ausziehbare rollenbahnen
 Convoyeur extensible
 Rodillos extensibles

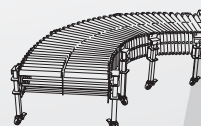

> **K-125 / K-250**

Inkjet printer
 Stampante ad inchiostro
 Tintenstrahldrucker
 Marqueur à jet d'encre
 Impresora de inyección de tinta

